

THE REQUIREMENTS FOR ACQUIRING THE PRODUCT(S) DESCRIBED HEREIN SHALL CONSIST OF THIS SPECIFICATION SHEET AND THE ISSUE OF THE FOLLOWING SPECIFICATION LISTED IN THAT ISSUE OF THE DODDSS SPECIFIED IN THE SOLICITATION: AS7477 (E)

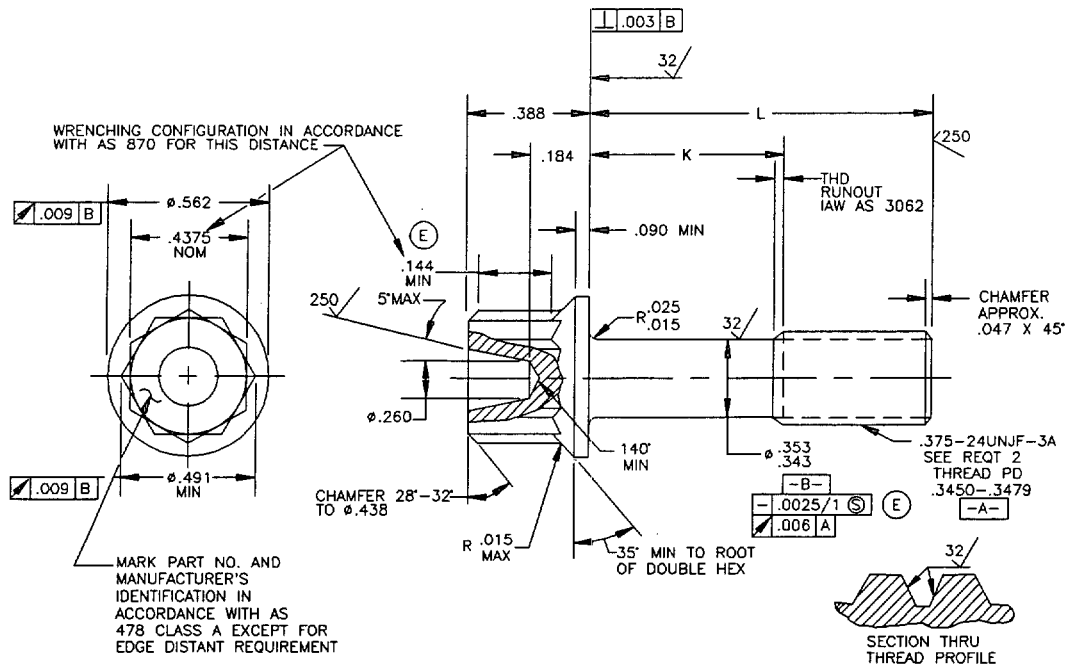

TABLE I. DASH NUMBERS AND DIMENSIONS

DASH NUMBER	L	K	APPROX WEIGHT LB/100	DASH NUMBER	L	K	APPROX WEIGHT LB/100	DASH NUMBER	L	K	APPROX WEIGHT LB/100
-03	.562	.088-.108	3.26	-21	1.688	.628-.688	6.27	-39	3.875	2.815-.2.875	12.14
-04	.625	.088-.108	3.42	-22	1.750	.690-.750	6.44	-40	4.000	2.940-3.000	12.47
-05	.688	.088-.108	3.58	-23	1.875	.815-.875	6.77	-41	4.125	3.065-3.125	12.80
-06	.750	.088-.108	3.74	-24	2.000	.940-1.000	7.11	-42	4.250	3.190-3.250	13.13
-07	.812	.088-.108	3.90	-25	2.125	1.065-1.125	7.44	-43	4.375	3.315-3.375	13.46
-08	.875	.088-.108	4.07	-26	2.250	1.190-1.250	7.78	-44	4.500	3.440-3.500	13.89
-09	.938	.088-.108	4.24	-27	2.375	1.315-1.375	8.11	-45	4.625	3.565-3.625	14.23
-10	1.000	.088-.108	4.41	-28	2.500	1.440-1.500	8.44	-46	4.750	3.690-3.750	14.56
-11	1.062	.088-.108	4.58	-29	2.625	1.565-1.625	8.78	-47	4.875	3.815-3.875	14.89
-12	1.125	.088-.125	4.75	-30	2.750	1.690-1.750	9.12	-48	5.000	3.940-4.000	15.23
-13	1.188	.128-.188	4.91	-31	2.875	1.815-1.875	9.46	-49	5.125	4.065-4.125	15.57
-14	1.250	.190-.250	5.08	-32	3.000	1.940-2.000	9.80	-50	5.250	4.190-4.250	15.90
-15	1.312	.252-.312	5.25	-33	3.125	2.065-2.125	10.13	-51	5.375	4.315-4.375	16.23
-16	1.375	.315-.375	5.43	-34	3.250	2.190-2.250	10.47	-52	5.500	4.440-4.500	16.58
-17	1.438	.378-.438	5.60	-35	3.375	2.315-2.375	10.80	-53	5.625	4.565-4.625	16.89
-18	1.500	.440-.500	5.76	-36	3.500	2.440-2.500	11.14	-54	5.750	4.690-4.750	17.23
-19	1.562	.502-.562	5.93	-37	3.625	2.565-2.625	11.47	-55	5.875	4.815-4.875	17.57
-20	1.625	.565-.625	6.10	-38	3.750	2.690-2.750	11.80	-56	6.000	4.940-5.000	17.91
								-57	1.812	.752-.812	6.61
								-58	1.938	.878-.938	6.94

(E) DENOTES CHANGE(S)

INCH - POUND

PREPARING ACTIVITY: DLA-IS  
CUSTODIANS: ARMY-AV NAVY-AS  
AIR FORCE-99 DLA-  
REVIEW: 82  
USER:  
PROJECT NUMBER: 5306-1707  
DISTRIBUTION STATEMENT

MILITARY SPECIFICATION SHEET  
TITLE  
BOLT, MACHINE-DOUBLE HEXAGON,  
EXTENDED WASHER HEAD, CORROSION AND  
HEAT RESISTANT STEEL, .375-24 UNJF-3A

SPECIFICATION SHEET NUMBER  
MS9559 2 SEP 93  
REV E  
SUPERSEDING  
MS9559 D 20 APR 93  
AMSC- N/A FSC 5306

A. Approved for public release; distribution is unlimited.

Page 1 of 2

THIS SPECIFICATION IS APPROVED FOR USE BY ALL DEPARTMENTS AND AGENCIES OF THE DEPARTMENT OF DEFENSE.

THE REQUIREMENTS FOR ACQUIRING THE PRODUCT(S) DESCRIBED HEREIN SHALL CONSIST OF THIS SPECIFICATION SHEET AND THE ISSUE OF THE FOLLOWING SPECIFICATION LISTED IN THAT ISSUE OF THE DODISS SPECIFIED IN THE SOLICITATION: AS7477 (E)

THIS SPECIFICATION IS APPROVED FOR USE BY ALL DEPARTMENTS AND AGENCIES OF THE DEPARTMENT OF DEFENSE.

**REQUIREMENTS:**

1. **MATERIAL:** CORROSION AND HEAT RESISTANT STEEL IN ACCORDANCE WITH AMS 5731-85.
2. **THREADS:** THREADS IN ACCORDANCE WITH MIL-S-8879. INCOMPLETE THREADS NOT TO ENTER FILLET.
3. **DIMENSIONING AND TOLERANCING:** DIMENSIONING AND TOLERANCING SHALL BE IN ACCORDANCE WITH ANSI Y14.5M.
4. **HEAD TO SHANK FILLET:** HEAD TO SHANK FILLET SHALL BE COLD ROLLED AFTER HEAT TREATMENT TO REMOVE ALL VISUAL EVIDENCE OF GRINDING OR TOOL MARKS EXCEPT DASH NUMBER SIZES -14 AND SMALLER.
5. **FLUORESCENT PENETRANT INSPECTION:** FLUORESCENT PENETRANT INSPECTION SHALL BE IN ACCORDANCE WITH AMS 2645-B3.
6. **SURFACE TEXTURE:** SURFACE TEXTURE, UNLESS OTHERWISE SPECIFIED, SHALL BE 125 MICROINCHES EXCEPT UPSET HEAD IN ACCORDANCE WITH ANSI/ASME B46.1.
7. **TOLERANCE:** UNLESS OTHERWISE SPECIFIED, TOLERANCES SHALL BE FOR LINEAR DIMENSIONS  $\pm .010$ , ANGULAR DIMENSIONS  $\pm 5^\circ$ .
8. **EDGES:** BREAK SHARP EDGES .003-.015 UNLESS OTHERWISE SPECIFIED.
9. **PART NUMBER:** THE PART NUMBER SHALL CONSIST OF THE BASIC MS NUMBER FOLLOWED BY A DASH NUMBER FROM TABLE.

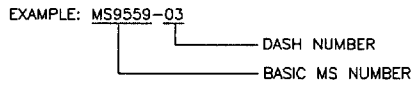

MS9559-03 INDICATES: BOLT, MACHINE-DOUBLE HEXAGON EXTENDED WASHER HEAD, .375-24 UNJF-3A, LENGTH .562

**NOTES:**

1. ALL DIMENSIONS IN INCHES.
2. DO NOT USE UNASSIGNED PART NUMBERS.
3. IN THE EVENT OF A CONFLICT BETWEEN THE TEXT OF THIS STANDARD AND THE REFERENCES CITED HEREIN, THE TEXT OF THIS STANDARD SHALL TAKE PRECEDENCE.
4. REFERENCED GOVERNMENT (OR NON-GOVERNMENT) DOCUMENTS OF THE ISSUE LISTED IN THAT ISSUE OF THE DEPARTMENT OF DEFENSE INDEX OF THE SPECIFICATIONS AND STANDARDS (DODISS) SPECIFIED IN THE SOLICITATION FORM A PART OF THIS STANDARD TO THE EXTENT SPECIFIED HEREIN.
5. THIS STANDARD WAS DEVELOPED COOPERATIVELY WITH THE SAE AEROSPACE PROPULSION DIVISION.
6. AS AND AMS ARE SAE PUBLICATIONS.

PREPARING ACTIVITY: DLA-IS CUSTODIANS: ARMY-AV      NAVY-AS AIR FORCE-99      DLA- REVIEW: 82 USER: PROJECT NUMBER: 5306-1707	<b>MILITARY SPECIFICATION SHEET</b> TITLE BOLT, MACHINE-DOUBLE HEXAGON, EXTENDED WASHER HEAD, CORROSION AND HEAT RESISTANT STEEL, .375-24 UNJF-3A	SPECIFICATION SHEET NUMBER <b>MS9559</b> 2 SEP 93 REV E SUPERSEDING MS9559 D      20 APR 93 AMSC-      N/A      FSC 5306
--	---	---

DISTRIBUTION STATEMENT      A. Approved for public release; distribution is unlimited.      Page 2 of 2